

MODEL SDF200

Description

- Superior European designed external rotor motor technology increases performances under any extreme restrictive duct design.
- Can be ceiling or wall mounted.
- Includes a hinged access door with integrated mounted motor to simplify period servicing.

Housing

- Painted galvanized steel housing.
- Hinged impeller for ease of cleaning and maintenance.
- Built in Back draft damper
- It holds a cETLus evaluation and confirms to UL and cUL safety standards.



Motor/Blower

- Capacitor start external rotor 4 pole motor comes with a lifetime lubrication for continuous operation.
- Motor comes with a built in overload disconnect for safety and longer motor life.
- Power rating should be 120 Volts and 60Hz
- Backward inclined blower wheel for smooth and quiet operation.

Mounting

- Designed to be ceiling or wall mounted.
- Supplied with two permanently attached brackets with predrilled holes for easy installation.
- Rubber grommets must be attached to isolate housing from the structure.

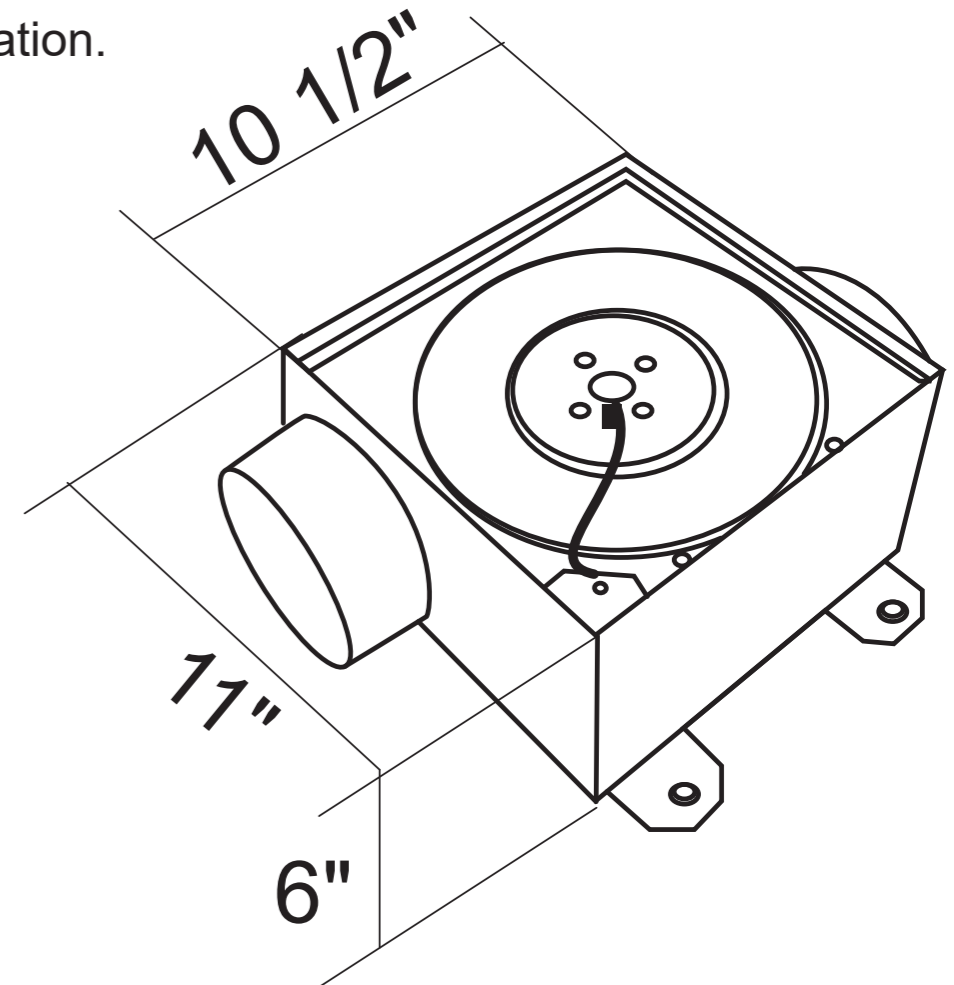

Add ons:

- AS-0 (Amp sensor)
- AS-S (Amp sensor)
- SDS-10(Pressure sensor)

	Dimension Data	Intake	Discharge
SDF200	10.5" X 11.0" X 6.0"	5"	5"

Model	0.1"	0.2"	0.3"	0.4"	0.5"	0.6"	0.7"	0.8"	0.9"	1.0"	Amps (FLA)	Fan Speed (RPM)	Sone
SDF200	206	203	196	190	183	176	168	160	153	144	0.9	2600	2.5

Reference	QTY.	Remarks	Project:
			Location:
			Architect:
			Engineer:
			Contractor:
			Submitted by:
			Date:

CERTIFICATIONS



ORTECH INDUSTRIES INC.

13376 Comber Way,
Surrey, BC, V3W 8V4
Canada
Phone: 1-888-543-6473



www.ortechindustries.com