

MODEL SDF200-2

Description

- Superior European designed external rotor motor technology increases performances under any extreme restrictive duct design.
- Can be ceiling or wall mounted.
- Includes a hinged access door with integrated mounted motor to simplify period servicing.

Housing

- Painted galvanized steel housing.
- Hinged impeller for ease of cleaning and maintenance.
- Built in Back draft damper
- Double inlet collars for dual exhaust.
- It holds a cETLus evaluation and confirms to UL and cUL safety standards.

Motor/Blower

- Capacitor start external rotor 4 pole motor comes with a lifetime lubrication for continuous operation.
- Motor comes with a built in overload disconnect for safety and longer motor life.
- Power rating should be 120 Volts and 60Hz
- Backward inclined blower wheel for smooth and quiet operation.

Mounting

- Designed to be ceiling or wall mounted.
- Supplied with two permanently attached brackets with predrilled holes for easy installation.
- Rubber grommets must be attached to isolate housing from the structure.

Add ons:

- AS-0 (Amp sensor)
- AS-S (Amp sensor)
- SDS-10(Pressure sensor)

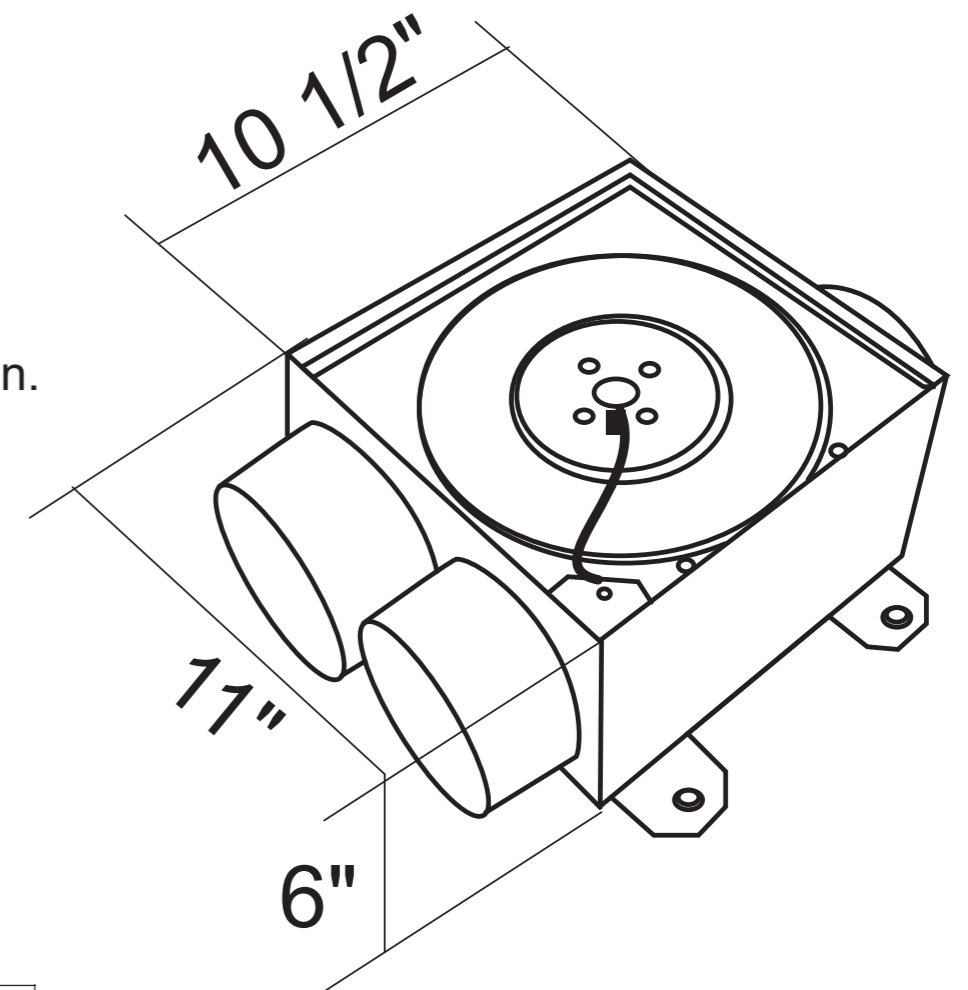

	Dimension Data	Intakes	Discharge
SDF200 -2	10.5" X 11.0" X 6.0"	4"	5"

Model	0.1"	0.2"	0.3"	0.4"	0.5"	0.6"	0.7"	0.8"	0.9"	1.0"	Amps (FLA)	Fan Speed (RPM)	Sone
SDF200 -2	235	222	211	205	195	186	175	169	158	150	0.9	2600	2.5

Reference	QTY.	Remarks	Project:
			Location:
			Architect:
			Engineer:
			Contractor:
			Submitted by:
			Date:

CERTIFICATIONS



ORTECH INDUSTRIES INC.

13376 Comber Way,
Surrey, BC, V3W 8V4
Canada
Phone: 1-888-543-6473



www.ortechindustries.com