

## MODEL OD-8005 OD-9005 OD-1109 OD-1209 OD-15011

### Ultra Silent, High Performance, Attractive Design Grille

#### Description

Ventilating fan should be ceiling mounted and capable of exhausting air quietly and efficiently. The Ortech Premium Series is HVI and Energy Star certified. It comes with a capacitor start motor which is known for its high efficiency and long lasting reliability. It holds an ETL evaluation and conforms to UL and cUL safety standards

#### Housing

Made of rugged 26 GA galvanized steel

Includes an attachable 6" metallic collar with build in back draft damper.

Double hanger bar mounting brackets that are adjustable up to 24 inch span allows for ideal positioning.

#### Motor/Blower

Plug in permanently lubricated motor- Engineered for continuous operation.

The motor is energy efficient and surpasses the minimum Energy Star requirements for continuous duty operation.

Power rating should be 120 volts and 60 Hz

Fan shall be ETL and cETL listed for tub/shower enclosure when used with a GFCI branch circuit. Motor comes with a built in overload disconnect for safety and longer motor life.

Our Premium series operates at lower RPM's to give you quieter operation.

#### Grille

The Premium grille is low profile that has elegance and still able to maintain its simplicity.

Made of a rugged polymeric resin that's known for its long life durability.

Comes with torsion spring clips that helps mount grille evenly.

#### Typical specification

Ceiling ventilator shall have corrosion resistance galvanized steel housing with 4 point mounting capability.

It shall be ducted to a roof vent or wall cap using 6 inch round pipe.

Blower assembly shall be removable, have a centrifugal type blower wheel and a permanently lubricated motor designed for continuous operation.

Includes an attachable 6" non metallic collar with build in back draft damper.

Air and sound delivery shall meet the HVI certified ratings as per the fan curves attached.

Ortech's Premium ventilators come with permanent split capacitor motor which improves efficiency this is why it has qualified to carry the Energy Star label.



#### Options

- LED/ Flourescent light
- Humidistat Motion Sensor
- Speed controller Metal Grille

Reference	QTY.	Remarks	Project:
			Location:
			Architect:
			Engineer:
			Contractor:
			Submitted by:
			Date:

#### CERTIFICATIONS



## MODEL OD-8005 OD-9005 OD-1109 OD-1209 OD-15011

Model Number	OD-8005		OD-9005		OD-1109		OD-1209		OD-15011	
Static Pressure in inches w.g.	0.1	0.25	0.1	0.25	0.1	0.25	0.1	0.25	0.1	0.25
Air Volume (CFM)	80	68	90	78	110	95	120	105	150	130
Noise (sones)	0.5		0.5		0.9		0.9		1.1	
Fan Watts	25W		25W		27W		27W		43W	
Duct Diameter	6"		6"		6"		6"		6"	
Power Rating(V/Hz)	120/60									

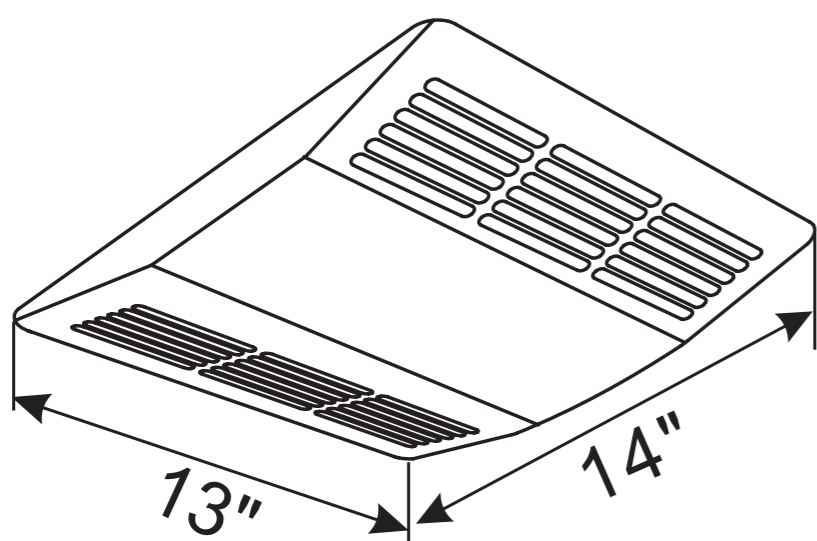
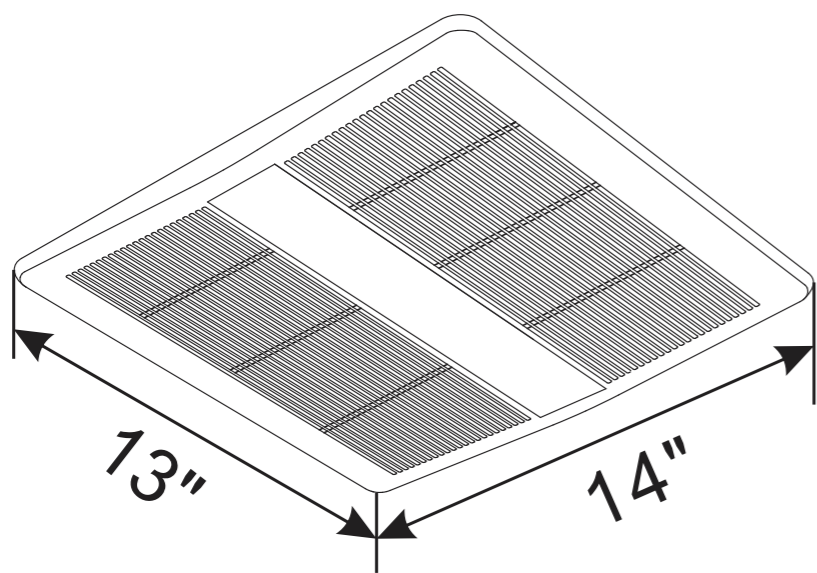
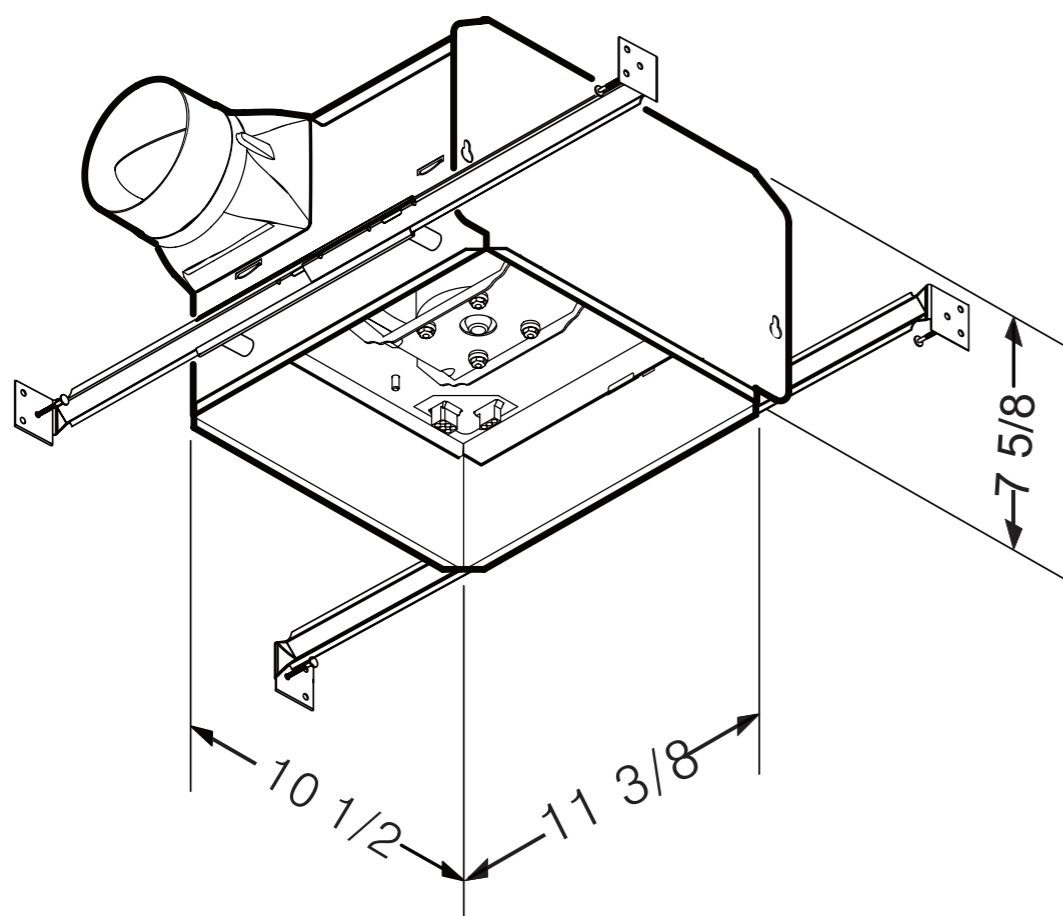

OPTIONAL METAL GRILLE

### OD-8005 OD-9005

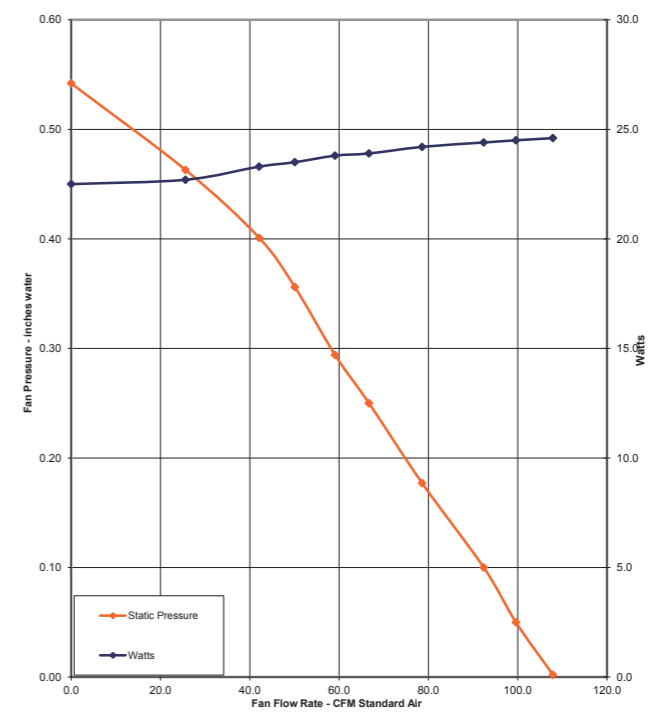

### OD-1109 OD-1209

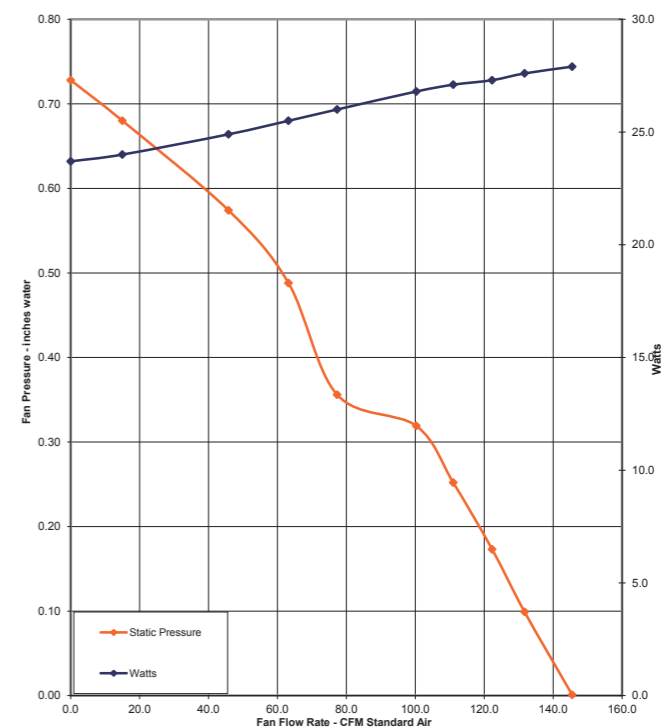

### OD-15011

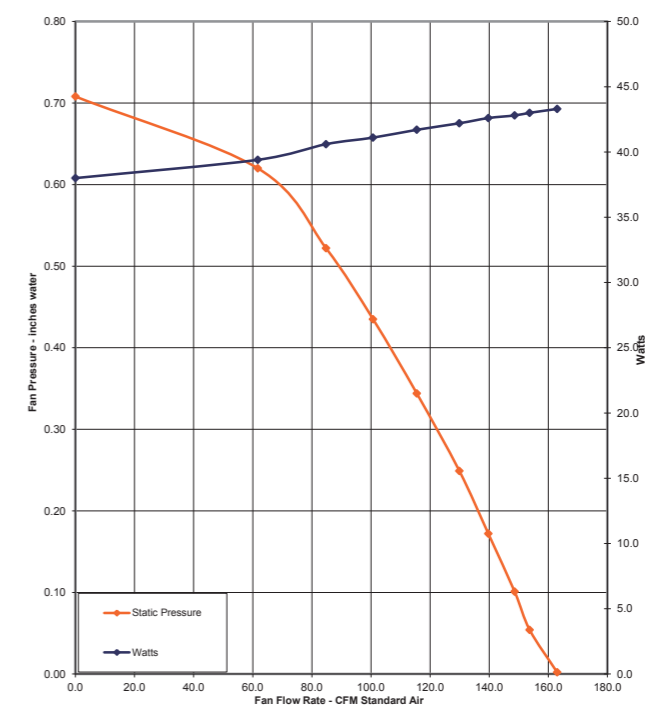

### CERTIFICATIONS

